

Operation manual

Computer controlled direct drive
button sewing machine

Texi X

 ***texi***®

CONTENTS

GENERAL SAFETY PRECAUTIONS.....	1
TECHNICAL SPECIFICATIONS.....	3
INSTALLATION OF MACHINE HEAD	3
LUBRICATION	3
INSERTING THE NEEDLE	4
ATTACHING THE NEEDLE BAR GUARD.....	4
ATTACHING THE BUTTON TRAY ASSEMBLY.....	4
THREADING THE MACHINE.....	5
THREAD TENSION ADJUSTMENT.....	5
ADJUSTMENT OF THE THREAD PULL-OFF LEVER.....	5
NEEDLE-TO-LOOPER RELATION.....	6
ADJUSTMENT OF THE NIPPER.....	6
POSITION OF THE NEEDLE GUIDE.....	7
HEIGHT OF THE BUTTON CLAMP.....	7
WORK PRESSING FORCE.....	7
ADJUSTMENT OF THE BUTTON CLAMP STOP LEVER.....	7
TIMING OF THREAD TENSION RELEASE.....	8
SETTING FOR 2- OR 4-HOLES BUTTONS.....	8
AUTOMATIC THREAD TRIMMER.....	8
STITCHES MODELS.....	9

PARTS BOOK

BUTTON CLAMP MECHANISM COMPONENTS.....	11
ARM & MISCELLANEOUS COVERS COMPONENTS.....	13
LOOPER SHAFT MECHANISM COMPONENTS.....	16
NIPPER & THREAD TENSION PARTS COMPONENTS.....	19
FEED PLATE COMPONENTS.....	22
BUTTON CLAMP LIFTER COMPONENTS.....	25
NEEDLE DRIVING PULLEY SHAFT COMPONENTS.....	28
	30
CE DECLARATION OF CONFORMITY.....	32

IMPORTANT!

This instruction manual contains important guidelines regarding correct, safe and economical method of use of the machine. Following recommendations contained in this manual will decrease work down-time, increase machine reliability and durability, and will make work safer.

This instruction manual must always be available at the workplace. The machine can be serviced only by an employee trained in Industrial Safety, after reading this instruction manual.

The supplier is not responsible for damages caused by improper use or by usage of this product for functions other than those it has been designed for.

GENERAL SAFETY PRECAUTIONS

To minimize the risk of fire, electric shock, or injury, observe the following precautions:

- Keep the workplace clean.
- Pay attention to the machine's work environment; do not subject it to atmospheric conditions.
- Do not install the machine in rooms that are dusty, where aerosols are sprayed, or to which oxygen is supplied.
- Keep the workplace well lit.
- Be careful of danger of electric shock.
- Pay attention to clothing. Let-down hair or loose clothing can be caught by the machine's mobile elements.
- Take care not to damage the power supply cable.
- When the machine is not in use, disconnect it from the power grid.
- Take care not to turn-on the machine accidentally.
- In case of even the slightest damage, always check if the damaged part requires replacement.
- Never install on the machine attachments and accessories other than those recommended by the manufacturer and supplier.
- Do not perform machine modifications independently.
- Do not leave near the machine unattended bystanders or children.

A safety shut-off switch has been installed in the machine, which protects the tilted head from accidental activation (for example, pressing the pedal).

Electric installation

Check if the supply voltage in the electric socket corresponds to the data on the machine's rating plate 1-phase voltage 230V 50Hz.

Check the correctness of electric connections in the plug and electric socket, **observing electric shock safety countermeasures.**

Do not use extension power cords.

Apply the valid electrical and Industrial Safety norms.

ATTENTION – all work related to the electrical installation must be carried out by a qualified electrician.

Before starting work

Using machine without any of the safeguarding parts (finger guard, eye guard, etc.) is dangerous to an operator.

During work, only the items necessary for sewing should be found on the machine's work table.

Before connecting the machine to the power grid, always release the pedal and the start button.

Do not use blunt or bent needles.

Do not touch any of the machine's mobile elements, such as the needle, needle bar, thread tensioner or take-up, or hook, during its operation.

Turn machine off before: replacing needle, threading, installing attachments, changing the bobbin or bobbin case.

If you notice any abnormalities in the machine's function, turn it off immediately and inform a mechanic or your superior. After finishing work, turn the machine off and remove the plug from the electric socket. In case of power grid failure, disconnect the machine from the power grid.

This machine is not a toy!

We hope that you will use this machine with pleasure for a long time.

USER'S MANUAL

The computer controlled direct drive button sewing machine TEXI, model X, is a high speed sewing machine, designed for sewing woven or knitted materials or other textiles.

The machine is equipped with a closed oil circulation system, thanks to which the amount of used oil has been reduced to the necessary minimum. The oil is located in a special closed container, instead of oil reservoir, thanks to which the risk of staining of sewed elements is eliminated.

Attention!

The machine is not to be used for other materials than those for which it has been designed.

Non-observance of this rule places the user at risk and can cause irreversible damage to the machine.

Before use, the user should become acquainted with this instruction manual, general safety precautions and maintenance instructions.

1. Before starting work

1. After turning-on the machine and during its operation, do not touch the needle or put fingers into the thread take-up guard.
2. During sewing, do not put fingers into the needle guard.
3. Before tilting the machine head or uninstalling guards, turn power off.
4. Turn machine off before leaving it unattended.
5. Do not allow hair, loose clothing, fingers or any objects to be in the vicinity of the pulley during machine run.
6. Do not clean the machine with paint thinner.

TECHNICAL SPECIFICATIONS

	TEXI X
Sewing speed	Max. 1,600 rpm (Normal 1,500 rpm)
Number of stitches	8, 16 and 32 stitches (6, 12 and 24 by changing the cam)
Feed amount	Lateral feed 2.5 to 6.5 mm Longitudinal feed 0, 2.5 to 6.5 mm
Button size	10 to 28 mm
Needle	TQx1 #16 (#14 to #18) TQx7 #16 (#14 to #20)
Lubricating oil	SPIRIT 2

INSTALLATION OF MACHINE HEAD

Put rubber cushion (1) on the table, place the machine head on the rubber cushion and fix it to the table using screws (2), plain washers (3) and nuts (4).

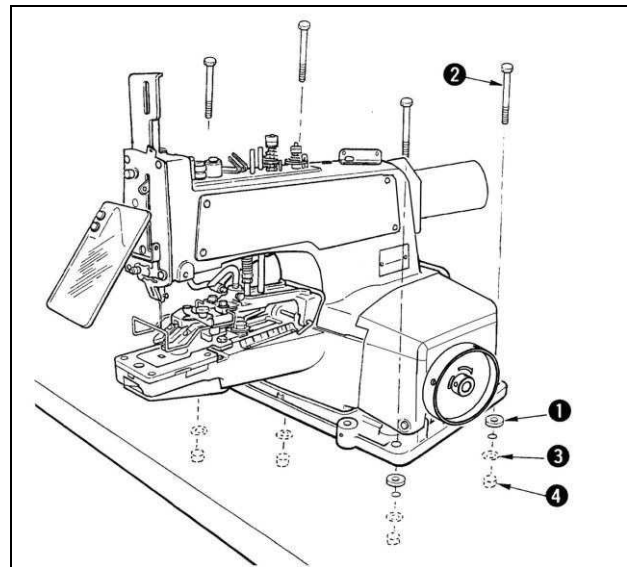

LUBRICATION

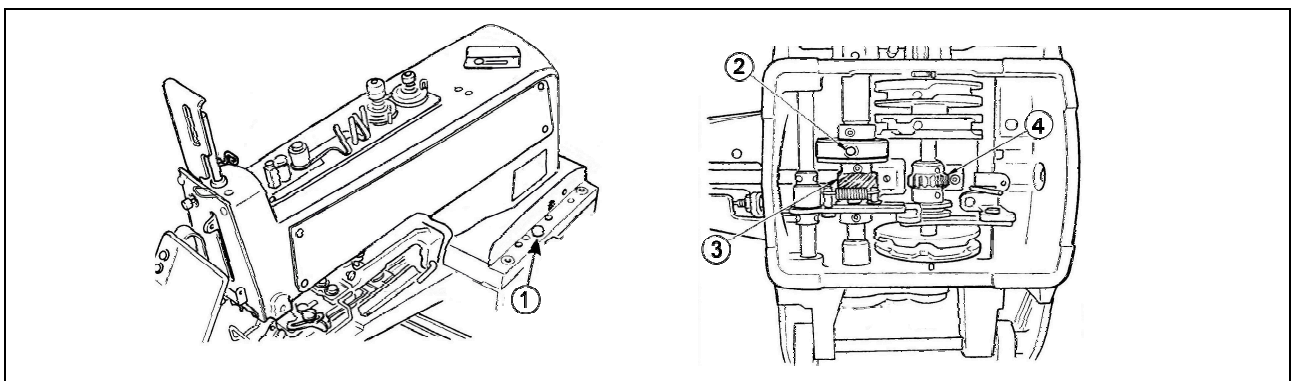

Apply vaseline oil for sewing machines Spirit 2 to the components shown by the arrows. (Once or twice a week) Loosen connecting screw (1), tilt the head backward and apply some grease to driving worm gear (3) and gear (4). Check, approximately once a week, that oil amount is sufficient to reach the top of the oil felt placed inside the bed mounting base. If the amount of oil is insufficient, add an adequate amount of oil. At this time, also apply oil to crank rod (2).

INSERTING THE NEEDLE

1. Loosen screw (1)
2. Insert needle (2) as far as possible.
3. Tighten screw (1).

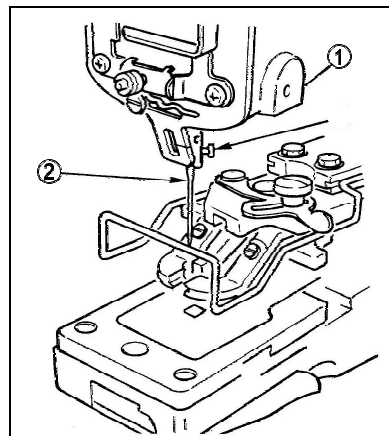

ATTACHING THE NEEDLE BAR GUARD

1. Loosen screw (2) and remove the thread guide.
2. Place needle guard under the thread guide.
3. Fix the thread guide and needle guard together using screw (2).

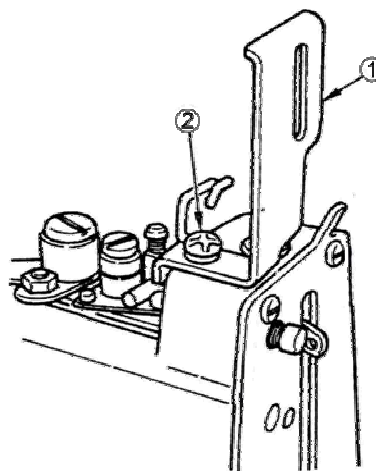

ATTACHING THE BUTTON TRAY ASSEMBLY

Insert the posts of button tray (1) in hole on the right of the machine sub-base and tighten each sets crew (2) .

You may use also the installation hole on the left.

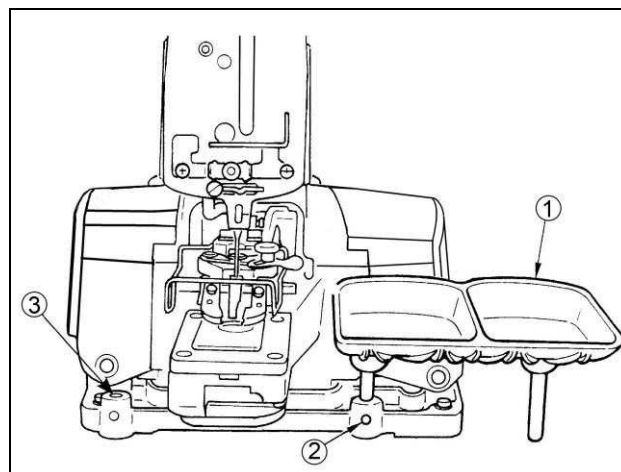

THREADING THE MACHINE

For threading the machine please check below drawing (thread the machine in order from 1-18).

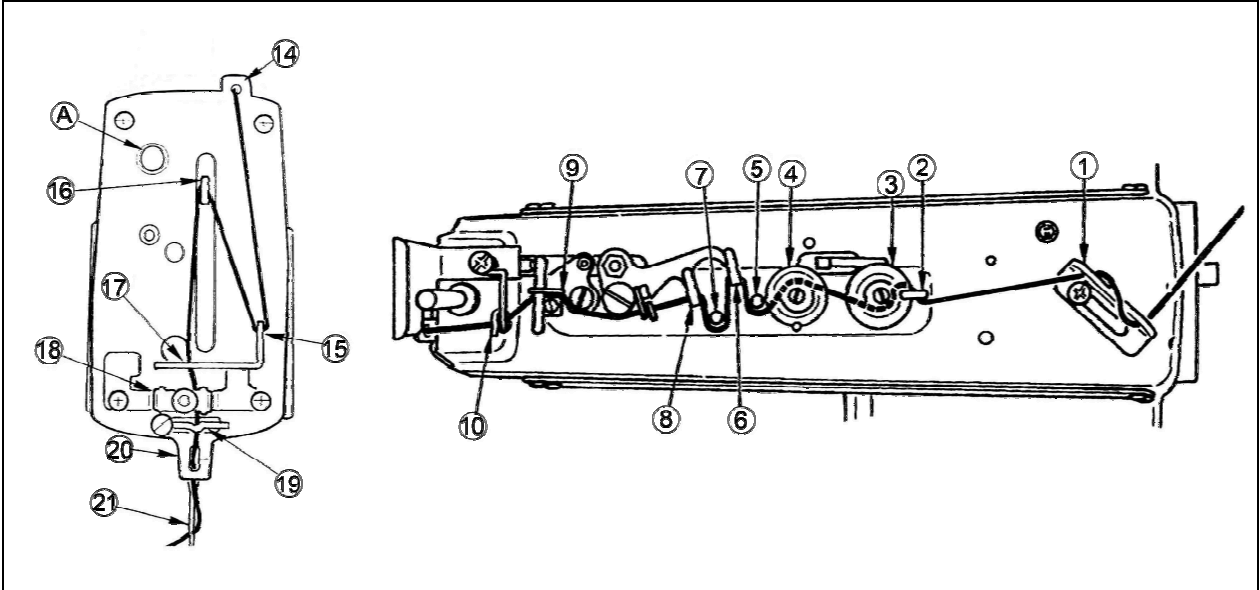

THREAD TENSION ADJUSTMENT

Tension post No.1 is used to adjust the thread tension to sew on the button and a relatively low tension will be enough.

Tension post No.2 is used to adjust the thread tension applied to the root of the button sewing stitches.

This tension must be determined according to the type of thread, fabric and thickness of the button and must be higher than tension set on post No.1 .

Turn the tension nuts clockwise to increase or counterclockwise to reduce the thread tension.

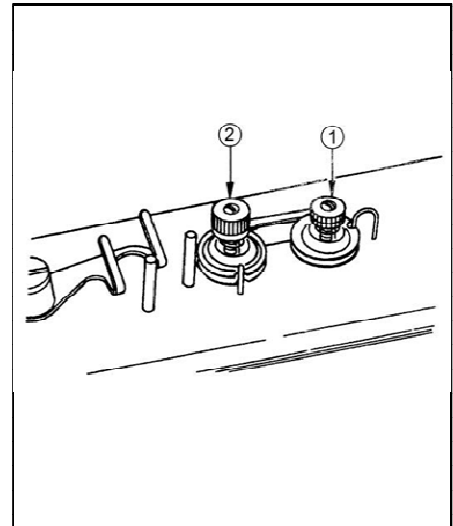

ADJUSTMENT OF THE THREAD PULL-OFF LEVER

To adjust the thread pull-off lever (1), insert a screwdriver through an opening in the machine arm side cover (left), loosen screw (2) and adjust the position of nipper bar block (rear) (3) to the left or the right.

If the end of thread is drawn from arrow hole A in the button after sewing, change the position of nipper bar block (rear) (3) to the left.

Move the lever to the right when the thread end comes out from arrow hole B.

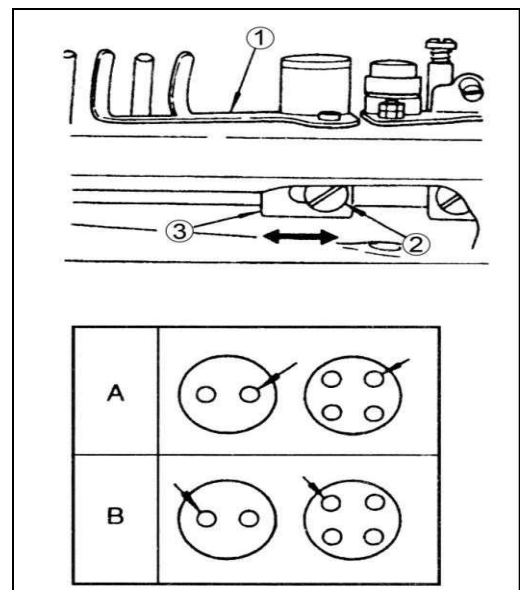

NEEDLE-TO-LOOPER RELATION

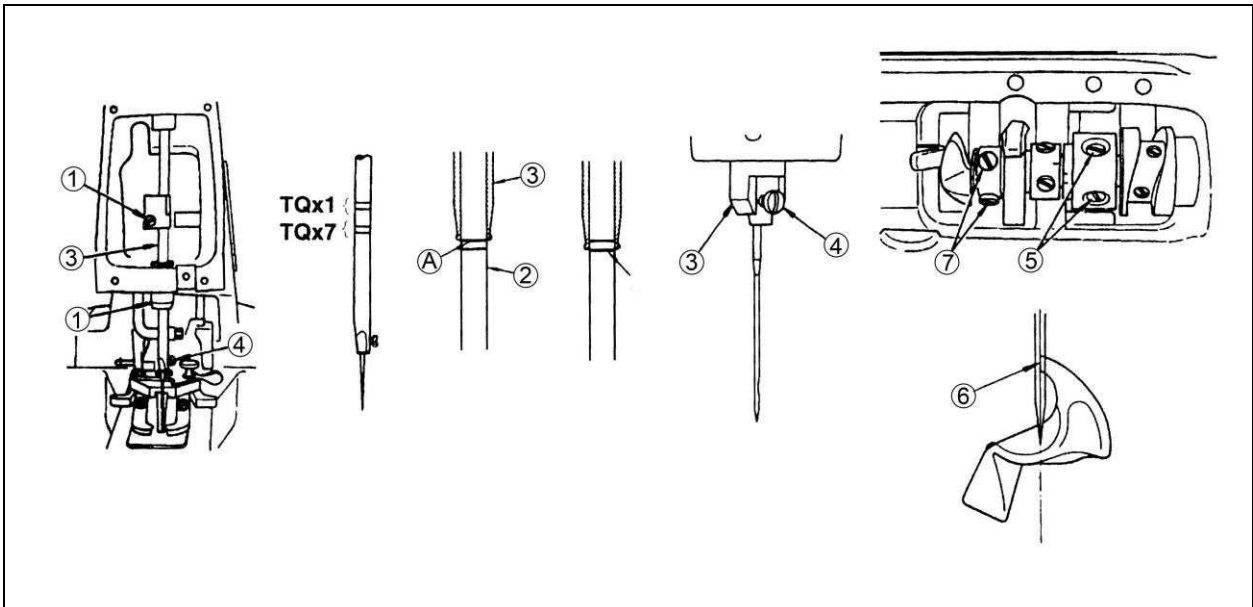

Adjust the needle-to-looper relation as follows:

1. Depress the pedal fully forward, turn the needle driving pulley in the normal sewing direction to bring down the needle bar to the lowest point and loosen screw (1) .

(Adjusting the needle bar height)

2. Adjust the height of the needle bar using top two lines engraved on the needle bar for the TQx1 needle and using the bottom two lines for the TQx7 needle.

Align the upper line A with the bottom end face of needle bar bushing (lower) (3) and tighten screw (1) in the way that needle clamp screw (4) rests in the slot of the needle bar bushing (lower) (3).

(Looper position)

3. Loosen screws (5) and turn by hand the needle driving pulley until lower line B of two lines aligns with the bottom end face of needle bar bushing (lower) (3).

4. By keeping the machine in this state, align looper blade (6) with the center of the needle and tighten screws (5).

5. Loosen screws (7) and provide a 0.01 to 0.1 mm clearance between the looper and the needle. Tighten screws (7).

ADJUSTMENT OF THE NIPPER

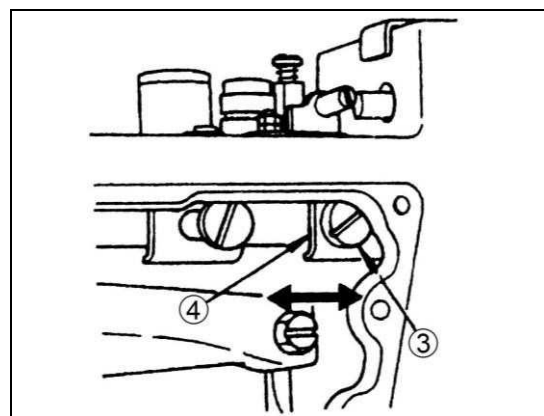
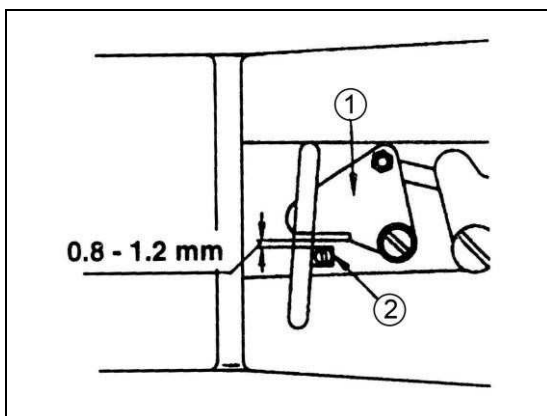

Provide 0.8 to 1.2 mm clearance between nipper (1) and nipper block (2) to prevent the nipper from nipping the thread while stitching. Loosen screw (3) and move nipper bar block (4) to the left or the right.

POSITION OF THE NEEDLE GUIDE

Loosen screw (2) and provide a 0.05 to 0.1 mm clearance between the needle guide (1) and the needle, by moving the needle guide (1) to the left or the right when the needle is in the lowest position.

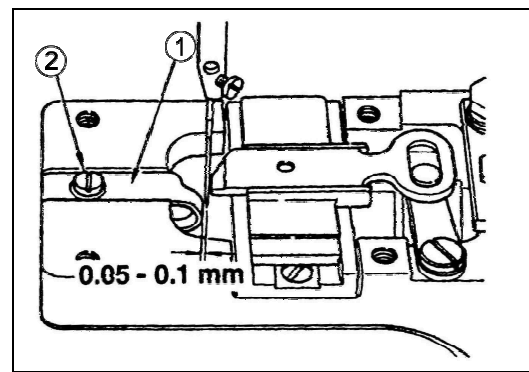

HEIGHT OF THE BUTTON CLAMP

The standard clearance (1) between the bottom face of button clamp jaw lever (2) and the top face of feed plate A is 9 mm for Texi X.

Loosen screw (3) and adjust the height of button clamp lifting hook (4).

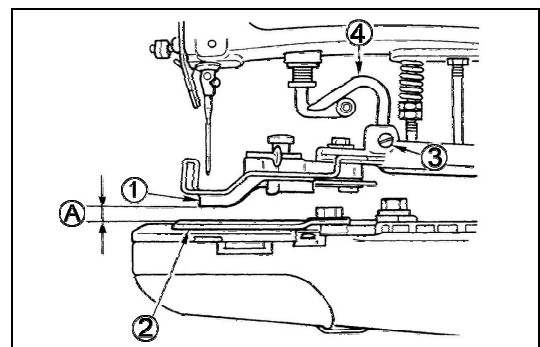

WORK PRESSING FORCE

The standard work pressing force is obtained by providing a 4 to 5 mm clearance between the bottom face of nut (1) and the bottom end of the screw of pressure adjusting bar (2).

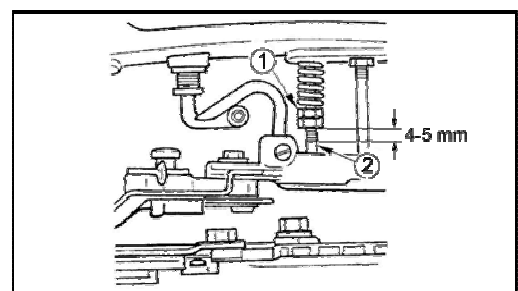

ADJUSTMENT OF THE BUTTON CLAMP STOP LEVER

Set the machine for stop-motion state, loosen clamp screw (1), place a button correctly in the sewing position and adjust button clamp stop lever (2) to permit the button properly to rest on button clamp jaw levers (3).

Tighten clamp screw after determining the distance between the left and right jaw levers (1).

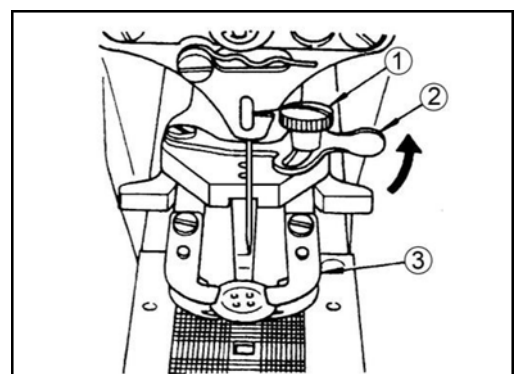

TIMING OF THREAD TENSION RELEASE

Turn the needle driving pulley as you draw the thread in the direction of the arrow as illustrated and you will find a point at which the tension disc on the tension post No. 2 release the thread. At this moment, the standard distance from the top end of the needle bar to the top end of the needle bar bushing (upper) is 44 to 47 mm. Perform the following adjustments especially when the undermentioned troubles occur frequently.

Loosen nut (1), insert the blade of a screwdriver to the top slot of the tension post No. 2 and turn it in the direction of the arrow to lower the needle bar, (to reduce the said distance), and vice versa.

Phenomenon	Height of needle bar
1. When the stitch made on the wrong side of the workpiece is too loose;	Make the needle bar slightly higher.
2. When the thread is broken at the time of stop-motion;	Make the needle bar slightly higher.
3. When the thread is broken frequently;	Make the needle bar slightly lower.

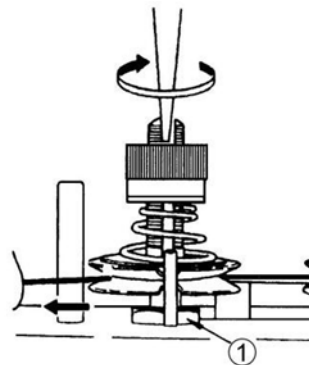

SETTING FOR 2- OR 4-HOLES BUTTONS

Measure the distance between two holes in a button and set equally crosswise and lengthwise feed regulators for 4-hole buttons.

Lengthwise feed

Push down lengthwise feed adjusting lever (1) and set it to 0 for 2-holes buttons or the corresponding amount for 4-holes buttons

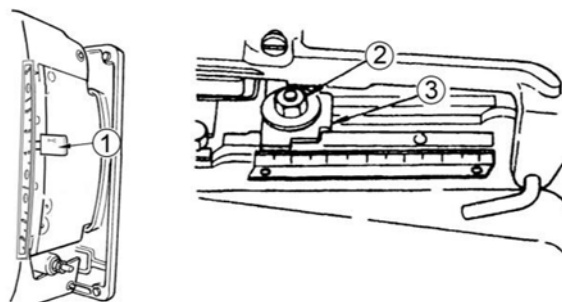

Crosswise feed

Loosen nut (2) and set pointer (3) to a corresponding amount indicated by the crosswise feed regulation plate. Tighten firmly nut (2).

Before operating the machine, ensure that the needle enters the centre of each hole in the button.

AUTOMATIC THREAD TRIMMER

Position of the moving knife

When the machine stops in the state of —stop-motion and its button clamp assembly rests in the highest position, there must be a standard clearance of 12.5 mm between thread trimming connecting link (front) (1) and the end face of the slit in throat plate (2). This clearance is determined by gauge (3) which is stored in the accessory box; tilt the head backwards, remove the bed oil shield, loosen two nuts (4) and adjust the clearance by moving connecting screw (5) in the axial direction. When you tighten two nuts (4), ensure that joint (6) stays in the horizontal position.

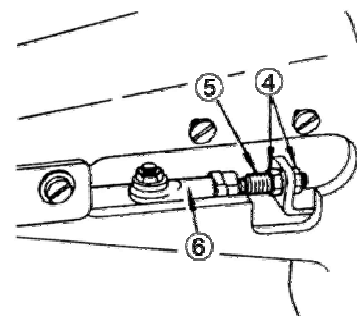
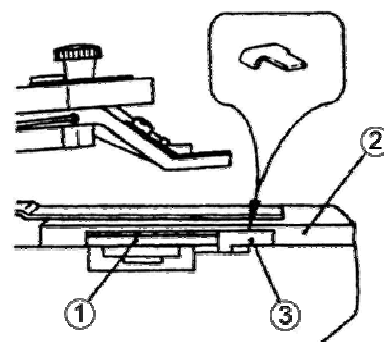

Height of the moving knife thread separation nail

There must be a 0.5 to 0.7 mm clearance between looper blade point (2) and thread separation nail (1). If nail (1) does not provide the necessary clearance, bend the nail slightly and adjust the clearance.

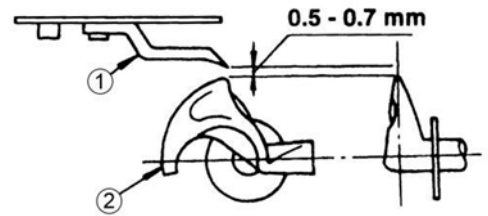

Clearance between the button clamp lifting lever and the adjusting screw

Provide a 0.5 mm clearance between button clamp lifting lever (1) and adjusting screw (2) and then tighten nut (3).

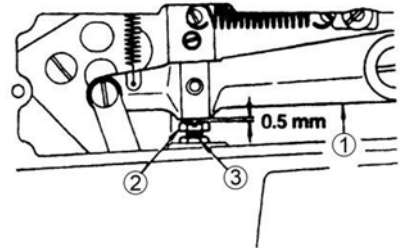

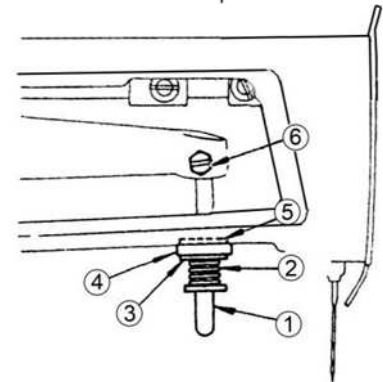

How to set the L-shaped lifting rod

Put moving knife push-back spring (2), stop-motion rubber cushion washer (3), stop-motion rubber cushion (4) and stop-motion rubber cushion washer (5), in this order, to L-shaped lifting rod (1). After making sure that the stop-motion mechanism has engaged completely, fix the L-shaped lifting rod by tightening screw (6) in the way that the end face of the stop-motion rubber cushion washer come into close contact with the jaw of the machine arm.

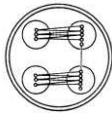

STITCHES MODELS

TEXI X	
8 , 16 , 32stitches	8 , 16 , 32 stitches
	

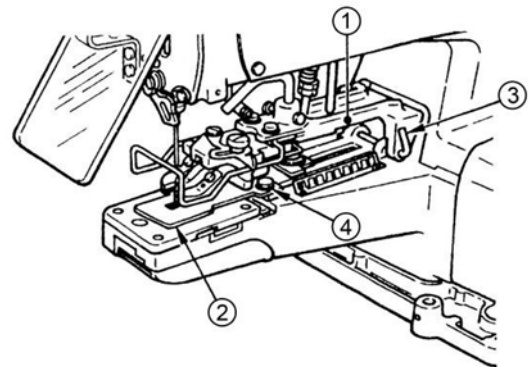

In order to install the attachment on the machine, you may have to remove the button clamp mechanism (1) or feed plate (2). Dislocate a snap ring from button clamp installing stud (3) , and you will be able to remove button clamp mechanism assembly (1) Loosen sets crews (4) , and you can remove feed plate (2) .

TROUBLES	CAUSES	CORRECTIVE MEASURES
1.Thread breakage	<p>The yoke slide does not move in the correct way.</p> <p>The thread tension post No. 2 fails to release the thread at correct timing,</p> <p>The thread nipper catches the thread</p> <p>The needle does not enter the center of the holes in the button.</p> <p>The needle is too thick for the diameter of the hole in the button.</p>	<p>Adjust the timing of the motion of the yoke slide at each end.</p> <p>Make the thread release timing slightly earlier.</p> <p>Adjust the position of the nipper bar block.</p> <p>Adjust the button clamp jaw lever holder.</p> <p>Replace the needle by a thinner one.</p>
2.Buttons are not sewn tightly	<p>The yoke slide does not move in the correct way.</p> <p>The thread tension post No. 2 fails to release the thread at correct timing.</p> <p>The thread tension post No. 2 does not give sufficient tension.</p> <p>The needle does not enter the center of the holes in the button.</p> <p>The work pressing force is too high or too low.</p>	<p>Adjust the timing of the motion of the yoke slide at each end.</p> <p>Make the thread release timing slightly later.</p> <p>Tighten the tension nut of tension post No.2.</p> <p>Adjust the button clamp jaw lever holder.</p> <p>Adjust the work pressing force properly.</p>
3.The first stitch trails relatively Jong thread from the right side of the button	<p>The thread pull-off lever does not work properly.</p>	<p>Ø Adjust the thread pull-off lever by the nipper bar block (rear).</p>
4.Thread trimming failure in the state of stop- motion	<p>The thread tension post No. 2 fails to release the thread at correct timing.</p> <p>The needle hits the edge of the holes in the button.</p> <p>The button clamp assembly does not rise to the necessary height.</p> <p>The thread nipper fails to press the thread.</p> <p>The work pressing force is too high.</p>	<p>Make the thread release timing slightly later to give more tension to the stitches</p> <p>Adjust the button clamp jaw lever holder.</p> <p>Provide a 12 mm clearance between the feed plate and the button clamp jaw levers when rose.</p> <p>Adjust the nipper bar block.</p> <p>Adjust the work pressing force by the pressure adjusting nut.</p>
5.Thread trimming failure	<p>(1)The moving knife does not separate the thread on the fabric with its separation nail`</p> <p>(2) The needle does not enter the center of the holes in the button.</p> <p>(3)The last stitch skips.</p> <p>(4)The moving knife thread separation nail is too high or too low.</p>	<p>Adjust the position of the moving knife.</p> <p>Adjust the button clamp jaw lever holders.</p> <p>Adjust the looper.</p> <p>Adjust the height of the moving knife thread separation nail.</p>
6.The needle thread is cut in two places on the wrong side of the fabric	<p>The moving knife is set in wrong place.</p> <p>The moving knife thread separation nail is too high or too low.</p>	<p>Adjust the position of the moving knife when the machine is in the stop-motion state.</p> <p>Adjust the height of the thread separation nail.</p>
7.Button traits too long thread after thread trimming	<p>Timing of the moving knife motion is wrong.</p> <p>The button clamp assembly rises too much.</p>	<p>Adjust the position of the moving knife.</p> <p>Reduce the button clamp lift down to 9 mm.</p>

Parts Book

BUTTON CLAMP MECHANISM COMPONENTS

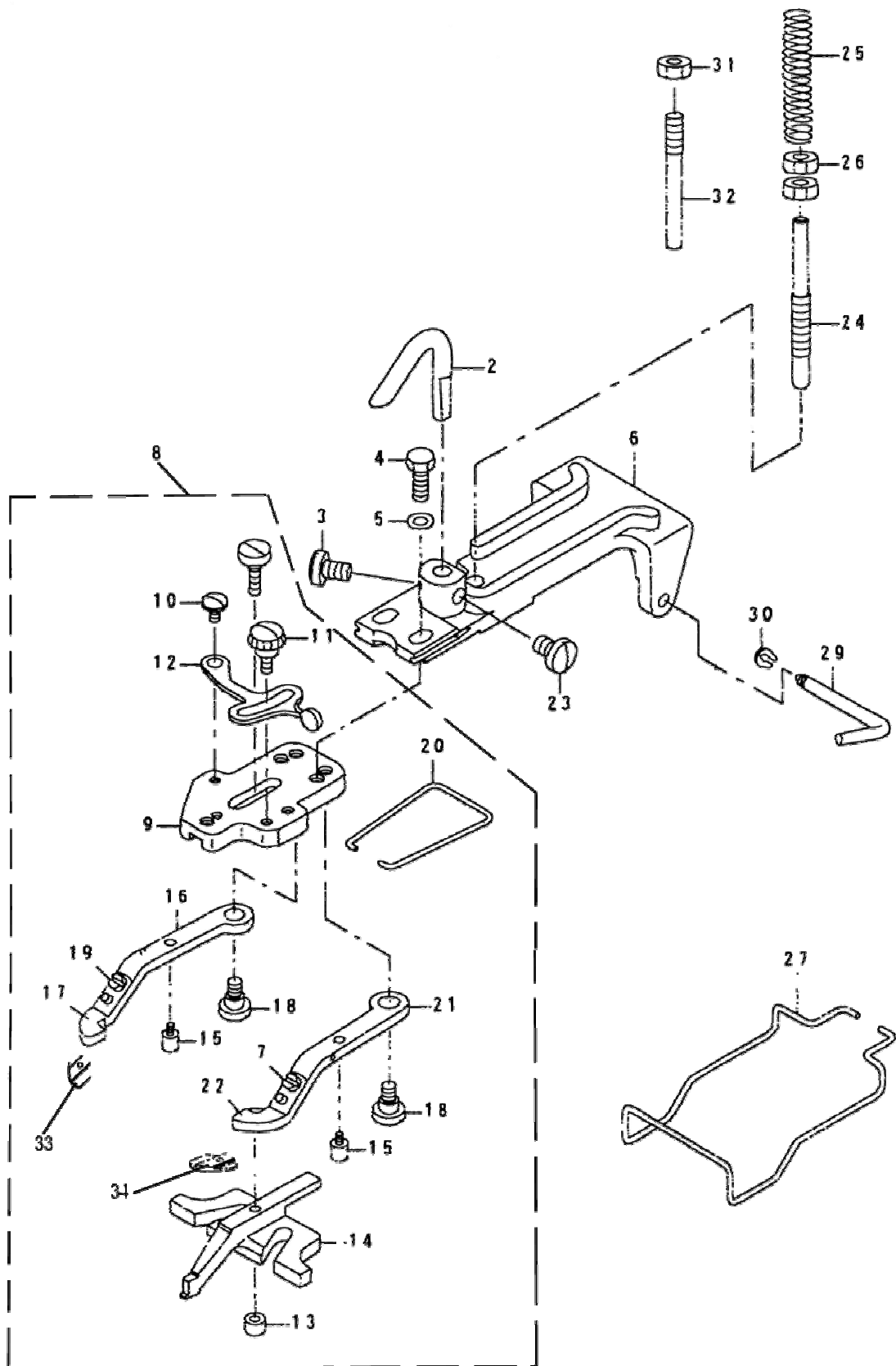

	code		DESCRIPTION
1	- - - - -	1	PICK-UP DEVICE ASM.
2	40902001	1	BUTTON CLAMP LIFTING HOOK
3	402S14006	1	SCREW 15/64-28 L=9
4	409S12001	2	SCREW 3/16-32 L=13.5
5	40928001	2	WASHER 5x10.5x1
6	300145	1	BUTTON CLAMP HOULDER
7	409S11002	1	SCREW 9/64-40 L=3.5
8	4091600100	1	BUTTON CLAMP
9	40912002	1	JAW LEVER HOLDER
10	409S20002	1	HINGE SCREW D=5.5 H=1.8
11	409S20003	1	CLAMP SCREW A
12	40912003	1	SNAP FASTENER CLAMP STOP LEVER
13	409S16001	1	NUT
14	40901003	1	BUTTON CLAMP SLIDE
15	409S20004	2	BUTTON CLAMP STOP PIN
16	40912005	1	BUTTON CLAMP LEVER JAW(LEFT)
17	40912006	1	BUTTON HOLDING SPRING LEFT
18	409S20005	2	HINGE SCREW D=6.35 H=3.9
19	409S11002	1	SCREW 9/64-40 L=3.5
20	40927001	1	BUTTON CLAMP SPRING
21	40912008	1	BUTTON CLAMP LEVER JAW RIGHT
22	40912009	1	BUTTON HOLDING SPRING RIGHT
23	402S14006	1	SCREW 15/64-28 L=9
24	409S30016	1	BUTTON CLAMP PRESSUER ADJUSTIN
25	40927002	1	PRESSUER ADJUSTING SPRING
26	409S16003	2	NUT M6
27	40927003	1	FINGER GUARD
29	40902002	1	HINGE PIN
30	H05007	1	SNAP PIN
31	401S16002	1	NUT 15/64-28
32	409S30001	1	PICK-UP DEVICE STOPPER PIN

ARM & MISCELLANEOUS COVERS COMPONENTS

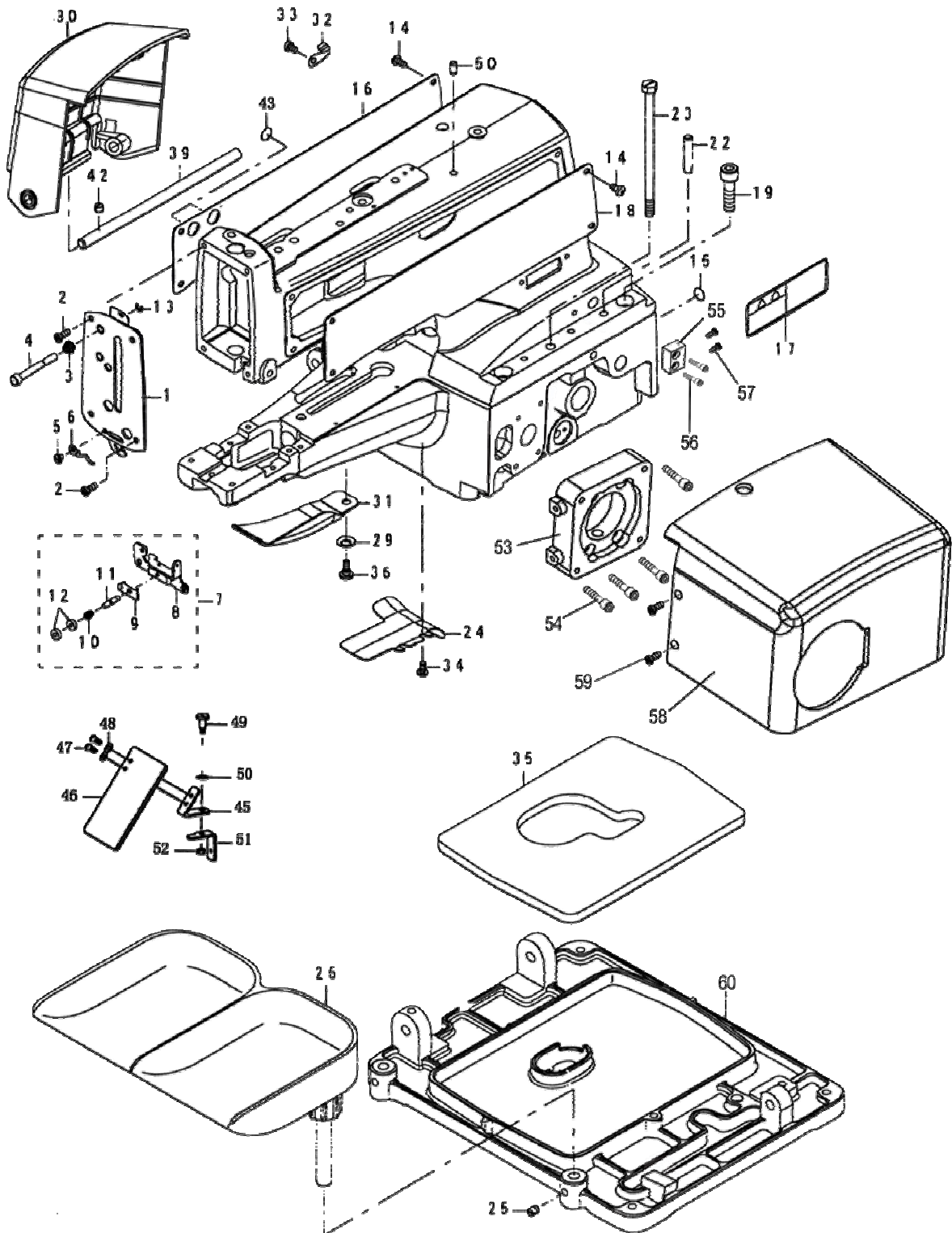

ARM & MISCELLANEOUS COVERS COMPONENTS

			DESCRIPTION
1	4091206200	1	FACE PLATE COMPL
2	406S11009	4	SCREW
3	40927004	1	TENSION SPRING
4	40902003	1	NIPPER RELEASING STOP
5	409S11003	1	SCREW
6	40913002	1	THREAD GUIDE NO.4
7	4091301400	1	THREAD TENSION NO.3 ASM.
8	40913015	1	TENSION ADJUSTING BASE NO.3
9	40913016	1	THREAD PRESSER PLATE
10	40927020	1	TENSION SPRING B
11	409S30017	1	THREAD TENSION STUD
12	409S16026	2	THREAD TENSION NUT
13	H05002	1	E-RING 3.2
14	406S11009	8	SCREW
15	40922005	1	RUBBER PLUG
16	40912063	1	SIDE COVER RIGHT
17	40937008	1	SAFETY LABEL
18	40912064	1	SIDE COVER LEFT
19	S05024	4	SCREW M8 L=30
22	P02001	2	GUIDE PIN
23	409S30018	1	SET SCREW
24	40912016	1	BED OIL SHIELD
25	402S14006	1	SCREW
26	4091100100	1	BUTTON TRAY ASM
29	40228001	1	SPRING WASHER 6.5x14.0x17
30	40911007	1	SIDE COVER LEFT
31	40912066	1	LOOPER COVER
32	40912067	2	SIDE COVER SPRING
33	409S11006	2	SCREW M4 L=6
34	409S11007	2	SCREW
35	40923013	1	OIL DRIP FELT
36	409S20006	1	SHOULDER SCREW D=6 H=2.7
39	40902019	1	SIDE COVER HINGE SHAFT LEFT
42	402S14006	1	SCREW M6 L=6
43	40122017	1	RUBBER PLUG
45	40112008	2	SAFETY PLATE
46	40911006	2	SAFETY PLATE
47	409S11008	2	SCREW M4 L=6
48	40928002	1	SPRING WASHER 5.0x110

49	402S20032	1	HINGE SCREW D=6 H=2.5
50	40128001	1	SPRING
51	40912020	1	SAFETY PLATE INSTALLING BASE
52	401S16004	1	NUT SM15/64-28
53	40901028	1	MORTOR BASE
54	413S13012	4	SCREW M5 L=20
55	40901032	1	FIXED SEAT
56	409S11003	2	SCREW SM3/16-28
57	406S11009	2	SCREW SM11/64-40
58	40911009	1	MOTOR COVER
59	409S11003	2	SCREW SM3/16-28
60	40901022	1	OIL RESERVOIR

LOOPER SHAFT MECHANISM COMPONENTS

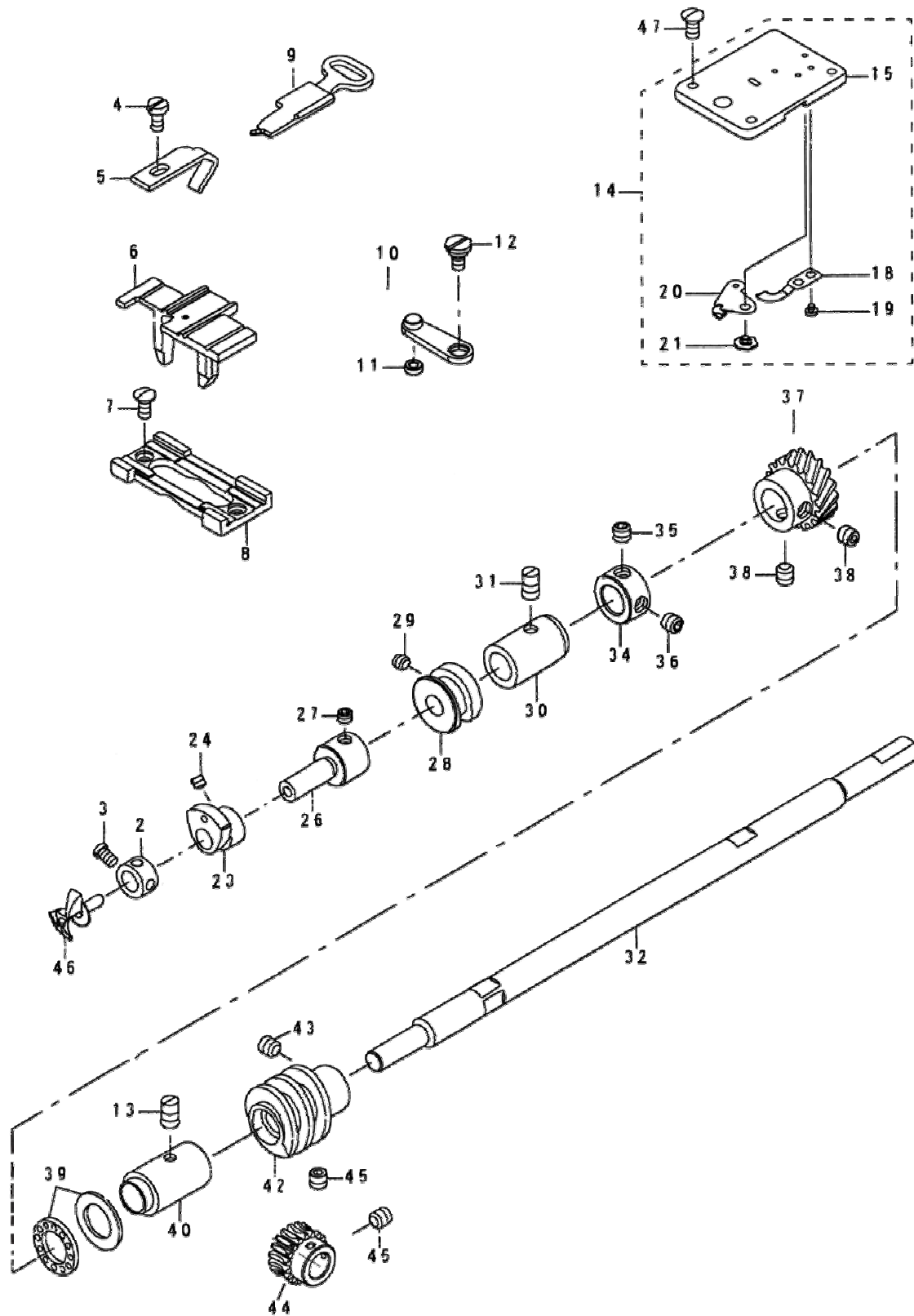

			DESCRIPTION
1	- - - - -	1	THRUST COLLAR .ASM
2	40908002	1	THRUST COLLAR D=7.94 W=7
3	409S11012	1	SCREW 9/64-40 L=6.1
4	409S11010	1	SCREW
5	40912021	1	NEEDLE GUARD
6	40909001	1	POSITONGNING FINGER YOKE SLIDE
7	409S17001	2	SCREW SM11/64-40 L=9
8	40909002	1	YOKE SLIDE INSERT
9	40912022	1	YOKE SLIDE
10	4090500100	1	ASSY LOOP POSITIONING FINGER L
11	40903003	1	LOOP POSITIONNING FINGER CAM RO
12	409S20008	1	HINGE SCREW D=6.35 H=2.4
13	401S14001	1	SCREW
14	- - - - -	1	THROAT PLATE SET
15	40901005	1	THROAT PLATE ASM.
18	40919003	1	COUNTER KNIFE
19	409S11011	2	SCREW 1/8-44 L=3.0
20	4091900100	1	MOVING KNIFE ASM.
21	409S20009	1	HINGE SCREW D=6 H=0.85
22	- - - - -	1	ASSY LOOP POSITIONING FINGER C
23	40910001	1	LOOP POSITIONING FINGER CAM
24	409S14002	2	SCREW 11/64-40 L=3.5
25	- - - - -	1	ASSY CAM AND LOOPER SLEEVE
26	40902006	1	CAM AND LOOPER SLEEVE
27	409S15004	2	SCREW 15/64-28 L=4.0
28	40910001	1	LOOP POSITIONGNING FINGER CAM RE
29	409S14002	2	SCREW 11/64-40 L=2.8
30	40903004	1	LOOPER SHAFT BUSHING FRONT
31	401S14001	1	SCREW
32	40902026	1	LOOPER SHAFT
33	- - - - -	1	THRUST COLLAR ASM, D=11.11,W=1
34	40908001	1	THRUST COLLAR ASM, D=11.11,W=10
35	409S14003	1	SCREW 1/4-40 L=5
36	409S14004	1	SCREW 1/4-40 L=5
37	40925002	1	LOOPER SHAFT DRIVER GEAR ASM.
38	409S14001	2	SCREW 1/4-40 L=6
39	40928004	1	THRUST BALL BEARING
40	40903005	1	LOOPER SHAFT BUSHING REAR
41	- - - - -	1	WORM WHEEL ASM.
42	40925009	1	WORM

43	409S14003	2	SCREW 1/4-40 L=7
44	40925001	1	CAM SHAFT ASM.
45	409S14003	2	SCREW 1/4-40 L=6
46	40917001	1	LOOPER
47	409S11009	3	SCREW M11/64-40 L=9

NIPPER & THREAD TENSION PARTS COMPONENTS

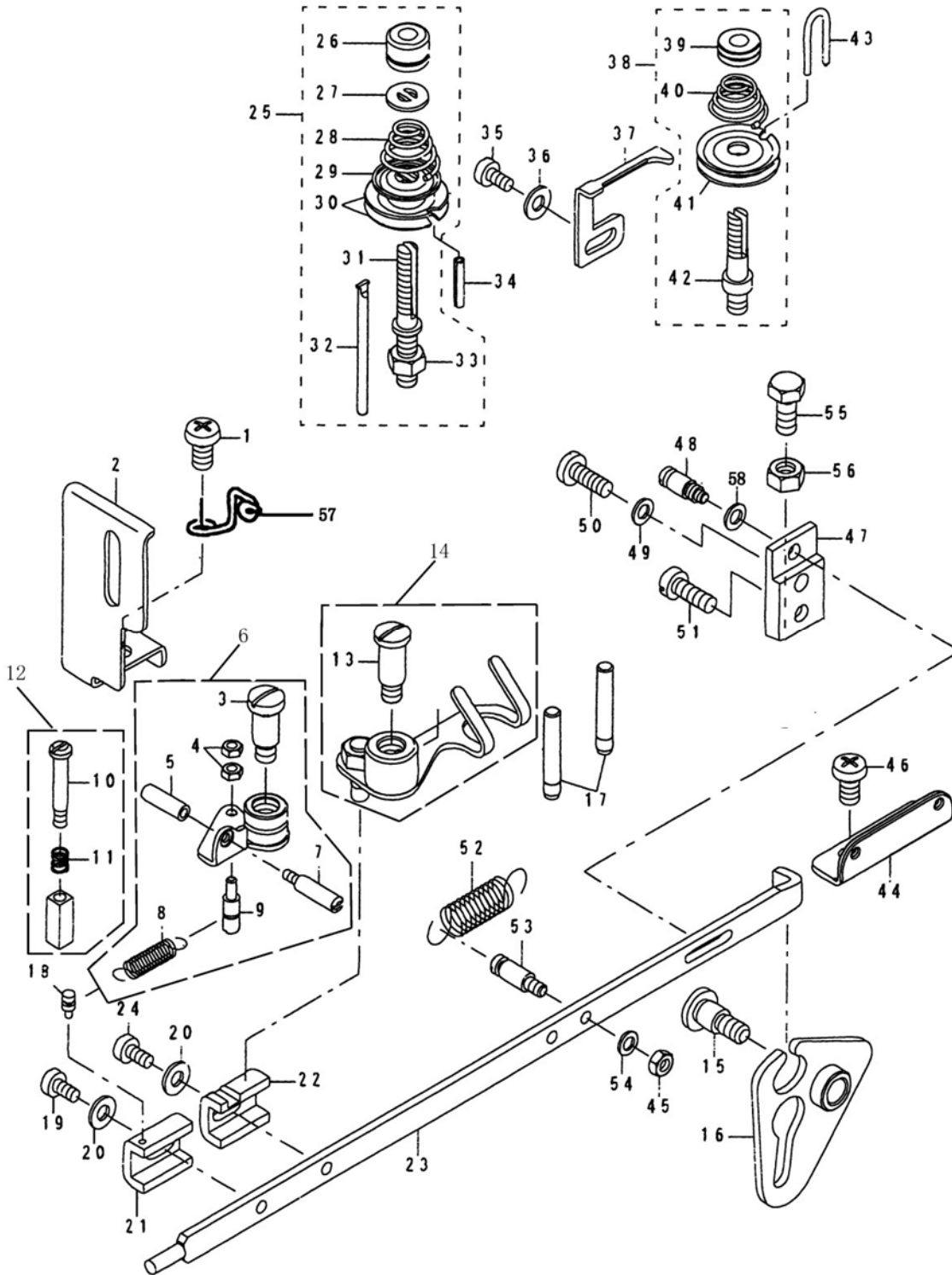

			DESCRIPTION
1	409S11013	1	SCREW SM15/64-28 L=12
2	40912024	1	NEEDLE BAR GUARD
3	409S20010	1	SHOULDER SCREW
4	409S16005	2	NUT
5	409S16006	1	NUT
6	4091202500	1	NIPPER COMPL
7	409S20011	1	LOOPER SHAFT BUSHING REAR
8	40927007	1	NIPPER BAR BLOCK SPRING
9	409S30004	1	NIPPER BAR BLOCK SPRING SCREW
10	409S20012	1	HINGE SCREW D=4 H=20
11	40927008	1	HIPPER SLIDE BLOCK SPRING
12	40909003	1	NIPPER BLOCK
13	409S20013	1	SHOULDER SCREW D=7.94 H=15
14	4091300400	1	THREAD PULL OFF LEVER ASM.
15	409S20014	1	SHOULDER SCREW D=7.94 H=8
16	4091202700	1	NIPPER BAR ACTUATING LEVER ASM.
17	40926006	2	THREAD GUIDE PIN
18	40926007	1	NIPPER BAR BLOCK SPRING PIN
19	409S11014	1	SCREW
20	40928004	2	WASHER
21	40912029	1	NIPPER BAR BLOCK
22	40912030	1	TENSION LEVER ROCKING PIECE
23	40912031	1	NIPPER BAR
24	409S11014	1	SCREW
25	4091300600	1	TENSION POST ASM NO.2
26	409S16007	1	TENSION NUT
27	40912032	1	ROTATION STOPPER
28	40927009	1	THREAD TENSION SPRING
29	40912033	1	THREAD TENSION DISK PRESSER
30	40913007	2	THREAD TENSION NO.1
31	409S30006	1	TENSION POST NO.2
32	409S16008	1	TENSION RELEASE PIN
33	40926008	1	NUT M6
34	P03009	1	SPRING PIN 3x16
35	409S11014	1	SCREW
36	40928004	1	WASHER
37	40912034	1	THREAD TENSION RELEASING LEVER
38	4091300800	1	ASSY HTREAD RENSIION NO.1
39	409S16009	1	THREAD TENSION NUT
40	40927010	1	FIRST THREAD TENSION SPRING

Parts book

41	40913007	2	THREAD RENSION DISK NO.1
42	409S30007	1	THREAD RENSION POST NO.2
43	40913009	1	THREAD GUIDE
44	40913010	1	THREAD GUIDE NO.1
45	409S16010	1	NUT
46	409S11013	1	SCREW
47	40912100	1	NIPPER BAR BEARING BLOCK
48	409S30008	1	ADJUSTING SCREW
49	40928005	1	WASHER 5.5x10x0.8
50	409S11015	1	SCREW
51	409S11016	1	SCREW
52	40927011	1	THREAD TENSION SPRING
53	409S30009	1	NIPPER BAR SPRING SCREW
54	40928006	1	WASHER
55	409S12002	1	SCREW
56	409S16011	1	NUT
57	40913012	1	THREAD GUIDE
58	40928005	1	WASHER 5x10.5x1

FEED PLATE COMPONENTS

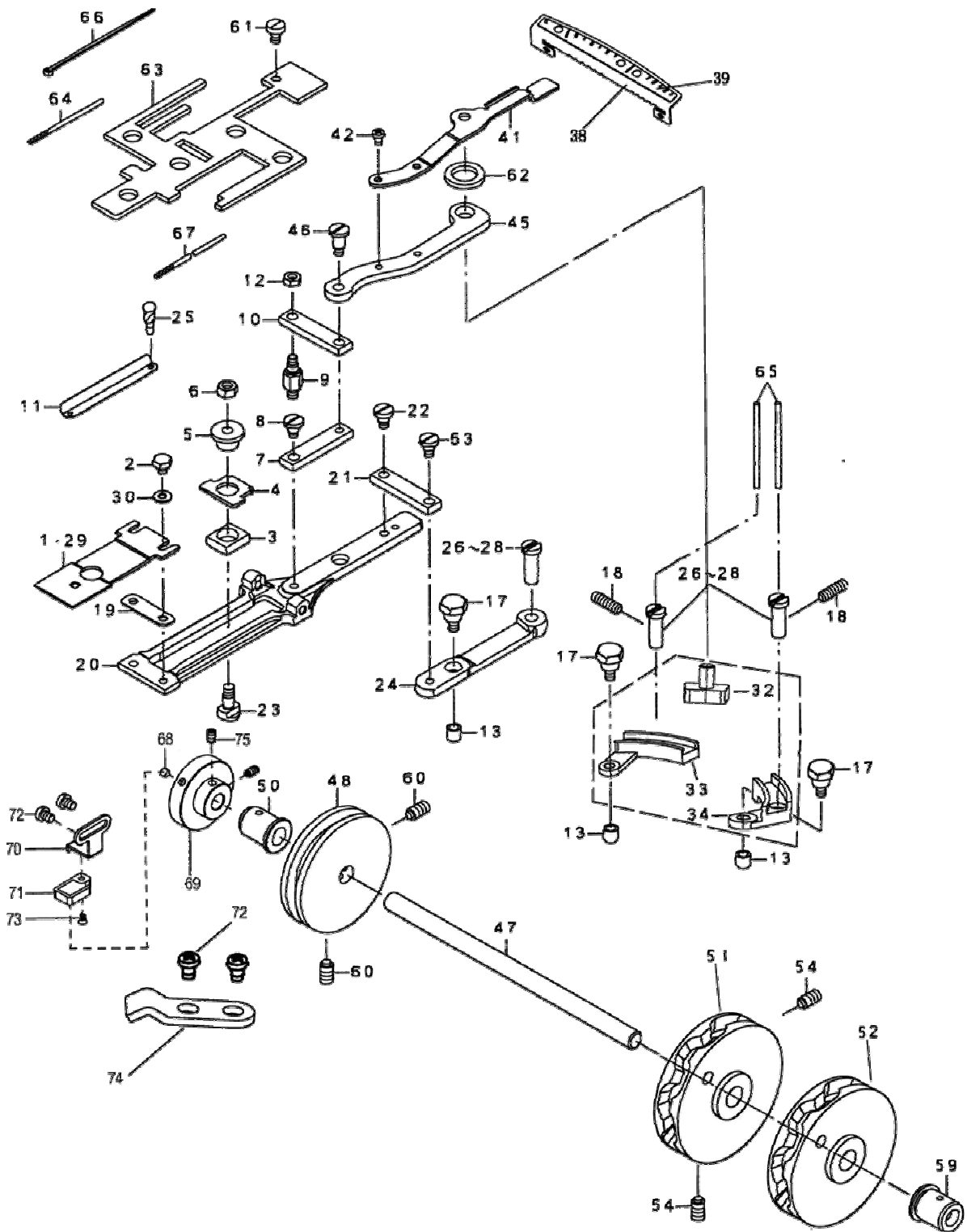

			DESCRIPTION
1	40915001	1	FEED PLATE SMALL BUTTON
2	409S12003	2	SCREW 3/16-28 L=6
3	40909004	1	INDICATOR PIN BEARING BLOCK
4	40912036	1	CROSSWISE FEED INDICATOR
5	40903010	1	CROSSWISE FEED INDICATOR PIN
6	409S16012	1	NUT M=6
7	400110	1	SLIDE PLATE CONNECTING LINK
8	409S20015	1	HING SCREW D=6.35 H=4.8
9	409S30010	1	STUD
10	400111	1	INTERMEDI CONNECTING LINK
11	40937001	1	CROSSWISE FEED GRADVATED PLATE
12	409S16013	1	NUT M5
13	40903012	2	CAM ROLL
17	409S30011	2	CAM ROLL SCREW STUD
18	401S14001	1	SCREW SM15/64-28 L=12
19	40912040	1	SPACER PLATE
20	40901006	1	FEED PLATE
21	40909006	1	INTERMEDI CONNECTING LINK
22	409S20015	1	HING SCREW D=6.35 H=4.8
23	409S30012	1	HING SCREW FOR CROSSWISE FEED
24	40904003	1	CROSSWISE FEED LEVER
25	R01002	5	RIVET
26	40902021	1	FEED STUD A
27	40902021	1	FEED STUD B
28	40902021	1	FEED STUD C
29	40915001	1	FEED PLATE SMALLBUTTON
30	40912068	2	WASHER 5x10.5x1
32	40909019	1	LENGTHWISE FEED LEVER SLIDE
33	40909020	1	FEED LEVER L
34	40909021	1	FEED LEVER R
35	40912069	2	FEED KNOB GUIDE PLATE
36	409S12006	1	SCREW M5x0.8 L=8
38	40912070	1	PLATE BASE
39	40911009	1	GRADUATE PLATE
41	40912071	1	HANDLE AND INDICATOR SPRING
42	409S11018	2	SCREW M4 L=6
43	409S11003	2	SCREE
45	40904004	1	INDICATOR SPRING CONNECTING LI
46	409S20016	2	SHOULDER SCREW D=6.35 H=9.7
47	40902022	1	CAM SHAFT
48	40910019	1	LENGRHWASE FEED CAM(X)

50	40903015	1	CAM SHAFT BUSHING LEFT
51	40910006	1	LATERAL FEED CAM
52	40910004	1	LONGITUDINAL FEED CAM
53	409S20015	1	SHOULDER SCREW D=6.35 H=4.8
54	401S14001	2	SCREW 9/32-28 L=13.5
59	40903013	1	CAM SHAFT BUSHING RIGHT
60	401S14001	4	SCREW 9/32-28 L=13.5
61	409S11005	1	SCREW M5 L=8
62	40923014	1	OIL RETAINING FELT
63	40923015	1	FEED SHOULDER SCREW FELT
64	40923008	0.06	OIL WICK
65	40923008	0.06	OIL FELT
66	40111005	4	CABLE BAND
67	40923008	0.3	OIL WICK
68	40930007	1	MAGNET
69	40930003	1	SINGLE WHEEL
70	- - - - -	1	HALL SWITCH HOLDER
71	- - - - -	1	HALL SWITCH
72	409S11003	2	SCREE
73	- - - - -	2	SCREE
74	41312003	2	WIRE BUCKLE
75	402S14006	2	SCREW 15/64-28

BUTTON CLAMP LIFTER COMPONENTS

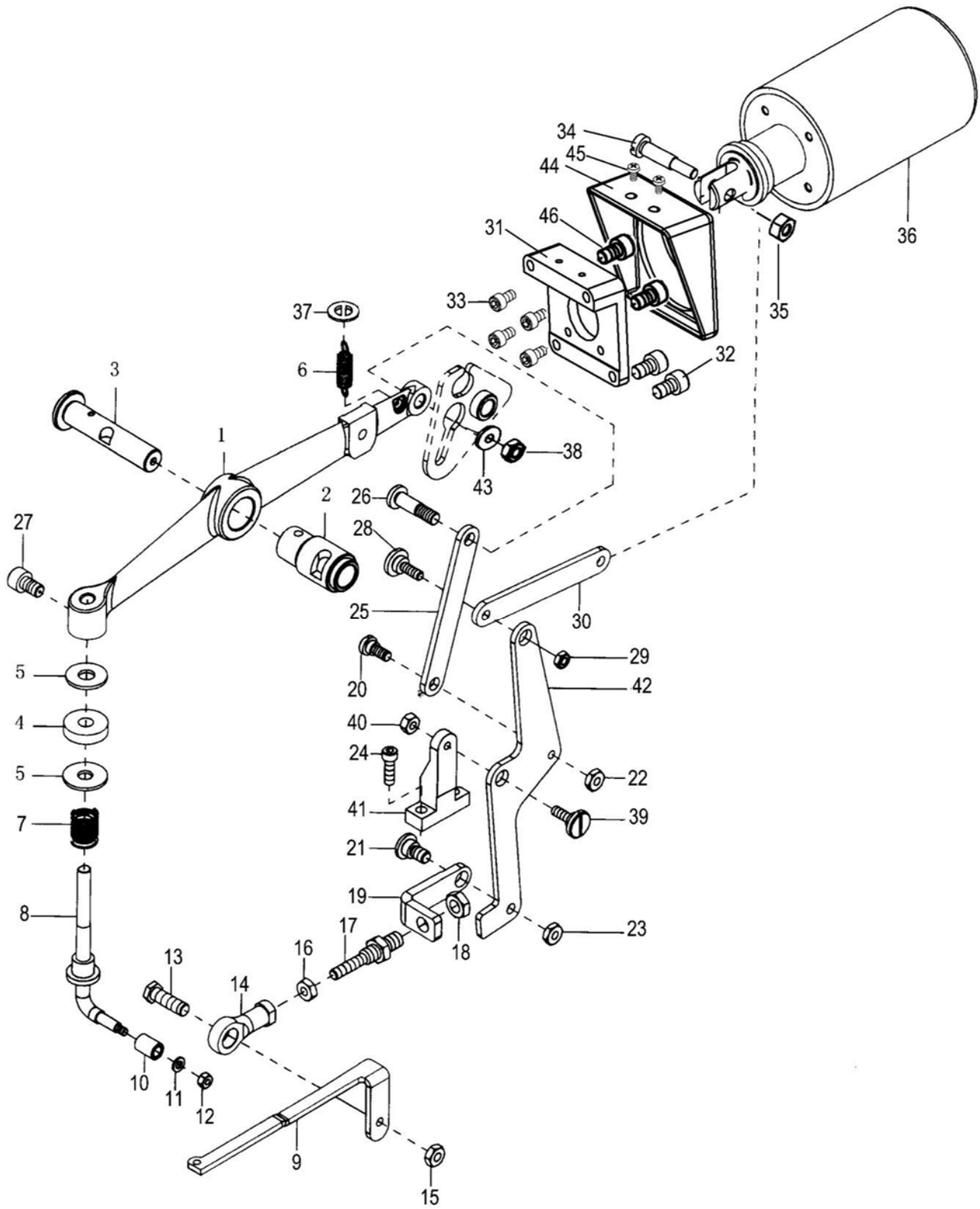

			DESCRIPTION
1	40901033	1	LIFTING LEVER
2	40903016	1	BUSHING
3	40902009	1	NDDELE BAR LEVER
4	40928014	1	WASHER 8.5x18.0x1.2
5	40922001	1	CUSHION
6	40927012	1	SPRING
7	40927013	1	SPRING
8	40912074	1	BUTTON CLAMP LIFTING ROD A
9	40912042	1	CONNECTING LINK FRONT
10	40903032	1	L TYPE LIFTING BAR ROLLER
11	40928021	1	WASHER
12	409S13003	1	NUT 9/64-40
13	L01002	1	JOINT STUD
14	4090500400	1	FEED ADJUSTING JOINT
15	N01004	2	NUT M5
16	409S16015	2	NUT
17	409S30013	1	CONNECTING SCREW
18	409S16015	2	NUT
19	40912043	1	CONNECTING LINK REAR
20	409S20020	1	HINGE SCREW D=6.35 H=3.2
21	409S20021	1	HINGE SCREW D=7.94 H=4
22	409S16016	1	NUT 3/16-32
23	409S16017	1	NUT 15/64-28
24	409S11021	2	SCREW 11/64-40 L=14
25	40905006	1	THREAD TRIMMING LINK
26	409S20023	1	HINGE SCREW D=6.35 H
27	S05023	1	SCREW M6 L=10
28	409S20038	1	HINGE SCREW D=6.35 H
29	401s16002	1	NUT 3/16-32
30	40912091	1	Magnet connect pole
31	40912092	1	Magnet holder
32	413S13019	4	SCREW M5 L=12
33	413S13016	4	SCREW M4 L=8
34	409S20039	1	PIN
35	413S16003	2	NUT M4
36	40930005	1	ELECTROMAGNET
37	40912032	1	WASHER
38	401S16002	1	NUT
39	409S20040	1	SHOULDER SCREW D=7.94 H=3.1

Parts book

40	409S16018	1	NUT M5
41	40901034	1	THREAD TRIMMING LEVER BASE
42	4091210000	1	CRANK ROD
43	40128034	1	WASHER
44	40911010	1	ELECTROMAGNET COVER
45	403S11027	2	SCREW M4 L=7.5
46	S05035	2	SCREW M5 L=25

NEEDLE DRIVING PULLEY SHAFT COMPONENTS

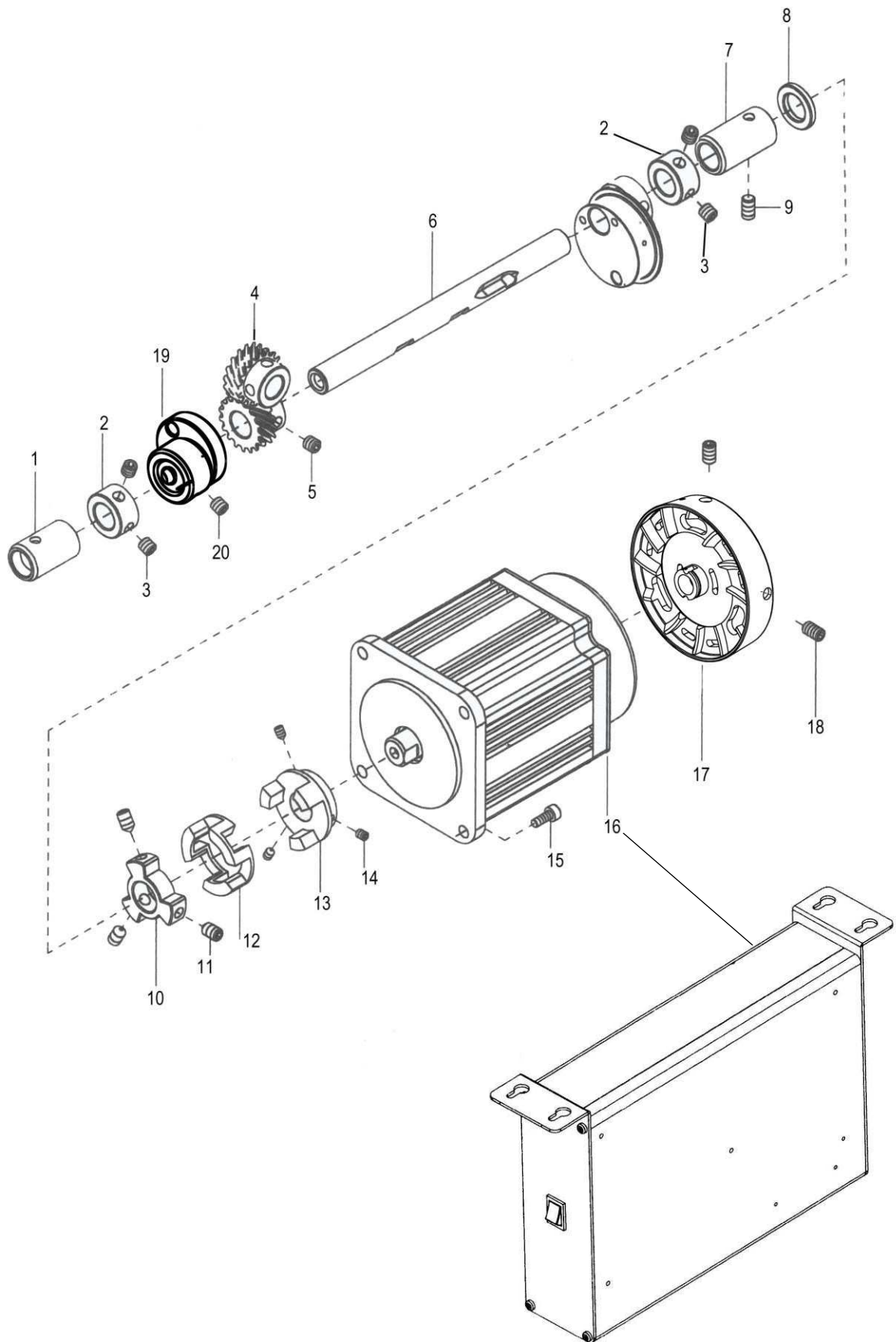

			DESCRIPTION
1	40903034	1	PULLEY SHAFT BUSHING LEFT
2	40603020	2	THRUST COLLAR
3	403S14004	2	SCREW M6
4	40925004	1	DRIVING GEAR(A) ASM.
5	409S14001	2	SCREW 1/4-40 L=6
6	40902024	1	NEEDLE DRIVING PULLEY SHAFT
7	40903024	1	PULLEY SHAFT BUSHING RIGHT
8	- - - - -	1	SPACE
9	401S14001	1	SCREW 15/64-28
10	40901030	1	MAIN SHAFT CONNECTOR
11	403S14004	3	SCREW M6
12	40222040	1	MAIN SHAFT CONNCECTOR WASHER
13	40201069	1	MOTOR CONNECTOR
14	403S14004	3	SCREW M6
15	S05035	4	SCREW
16	40933001	1	MOTOR
17	302443	1	PULLEY
18	403S14004	3	SCREW M6
19	40910007	1	ECCENTRIC CAM
20	409S14003	2	SCREW

NEEDLE BAR DRIVING MECHANISM COMPONENTS

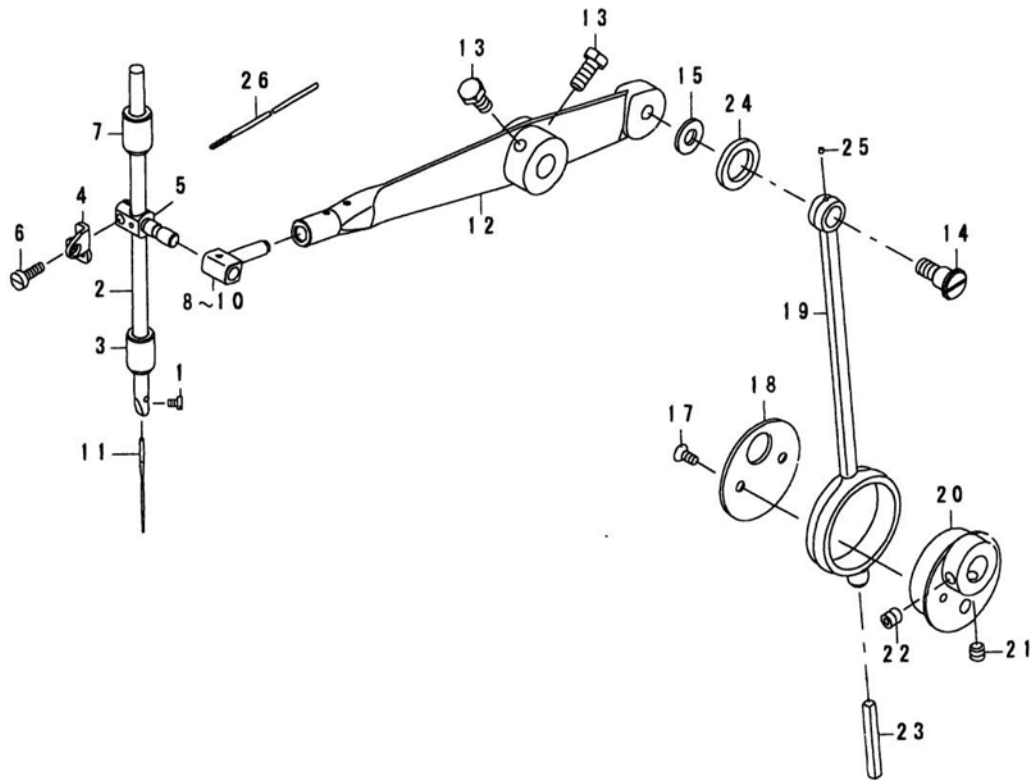

			DESCRIPTION
1	101S11006	1	SCREW 1/8-44 L=4.5
2	40902027	1	NEEDLE ROD
3	40903026	1	NEEDLE BAR BUSHING LOWER
4	40913013	1	NEEDLE BAR BALACE
5	40909016	1	NEEDLE BAR CLAMP
6	409S11024	1	SCREW M4 L=12
7	40903035	1	NEEDLE BAR BUSHING UPPER
8	40909016	1	NEEDLE BAR SLIDE BLOCK A
9	- - - - -	1	NEEDLE BAR SLIDE BLOCK B
10	- - - - -	1	NEEDLE BAR SLIDE BLOCK C
11	41017001	1	NEEDLE TQ×1 #16
12	40905007	1	NEEDLE BAR DRIVING LEVER
13	L02008	2	SCREW M6 L=14
14	409S20025	1	SHOULDER SCREW D=9.53 H=8
15	40928013	1	WASHER
16	- - - - -	1	CRANK ROD ASM.
17	409S11009	2	SCREW 11/64-40 L=8.5
18	40912046	1	THRUST HOLDER
19	40905009	1	CRANK ROD
20	40910009	1	ECCENTRIC CAM
21	40910009	1	SCREW 1/4-40 L=6
22	409S14001	1	SCREW 1/4-40 L=8.5
23	40923008	1	OIL WICK
24	40923014	1	OIL RETAINNING FELT
25	40923008	0.01	OIL WICK
26	40923008	0.1	OIL WICK

CE DECLARATION OF CONFORMITY

Distributor:

Strima Sp. z o.o.

Swadzim, st. Poznańska 54

62-080 Tarnowo Podgórne, Polska

We declare, that the following product:

Industrial button sewing machine

Texi X (JM-2377D)

which this declaration relates, complies with the following directives:

Machine directive 2006/42/WE

Low voltage directive 2006/95/WE

Harmonized norm used: EN 60204-1



Dealer:

--